

Dell PowerVault MD3800f and MD3820f Storage Arrays Owner's Manual

Regulatory Model: E03J and E04J Series
Regulatory Type: E03J001 and E04J001



Notes, cautions, and warnings

 **NOTE:** A NOTE indicates important information that helps you make better use of your computer.

 **CAUTION:** A CAUTION indicates either potential damage to hardware or loss of data and tells you how to avoid the problem.

 **WARNING:** A WARNING indicates a potential for property damage, personal injury, or death.

Copyright © 2015 Dell Inc. All rights reserved. This product is protected by U.S. and international copyright and intellectual property laws. Dell™ and the Dell logo are trademarks of Dell Inc. in the United States and/or other jurisdictions. All other marks and names mentioned herein may be trademarks of their respective companies.

2015 - 10

Rev. A01

Contents

1 About Your System.....	6
Introduction.....	6
Front-Panel Features and Indicators.....	6
Back-Panel Features and Indicators.....	9
Physical-Drive Indicator Patterns.....	9
Power Supply and Cooling Fan Features.....	10
Power Indicator Codes and Features.....	10
Related Documentation.....	11
2 Controller Modules.....	12
RAID Controller Modules.....	12
RAID Controller Module Connectors and Features.....	12
Host Channel LED Link Rate Indications.....	14
RAID Controller Module—Additional Features.....	14
Battery Backup Unit.....	14
Storage Array Thermal Shutdown.....	14
System Password Reset.....	15
Cache Functions and Features.....	15
Cache Mirroring.....	15
Write-Back Cache.....	15
Write-Through Cache.....	15
SFP Transceivers, Fiber Optic, and SAS Cables.....	16
Interoperability of 4 Gbps, 8 Gbps, and 16 Gbps Devices.....	17
3 Installing Array Components.....	18
Recommended Tools.....	18
Front Bezel (Optional).....	18
Removing the Front Bezel.....	18
Installing the Front Bezel.....	19
Physical Drives.....	19
SAFETY Models AMT E03J and E04J.....	19
Removing a 2.5 Inch Physical-Drive Blank.....	19
Installing a 2.5 Inch Physical-Drive Blank.....	19
Removing a 3.5 Inch Physical-Drive Blank.....	20
Installing a 3.5 Inch Physical-Drive Blank.....	20
Removing a Hot-Swap Physical Drive.....	20
Installing a Hot-Swap Physical Drive.....	21
Removing a Physical Drive From a Physical-Drive Carrier.....	22

Installing a Physical Drive Into a Physical-Drive Carrier.....	23
RAID Controller Module	23
Removing a RAID Controller Module Blank.....	24
Installing a RAID Controller Module Blank.....	24
Removing a RAID Controller Module	24
Installing a RAID Controller Module	25
Opening the RAID Controller Module	26
Closing the RAID Controller Module.....	27
RAID Controller Module Backup Battery Unit	27
Removing the RAID Controller Module Backup Battery Unit	27
Installing the RAID Controller Module Backup Battery Unit.....	28
Power Supply/Cooling Fan Module.....	28
Removing a Power Supply/Cooling Fan Module.....	29
Installing a Power Supply/Cooling Fan Module.....	30
Control Panel.....	30
Removing the Control Panel.....	30
Installing the Control Panel.....	31
Backplane.....	32
Removing the Backplane.....	32
Installing the Backplane.....	33

4 Troubleshooting Your System..... 34

Safety First—For You and Your System.....	34
Troubleshooting Storage Array Startup Failure.....	34
Troubleshooting Loss of Communication.....	34
Troubleshooting an SFP Transceiver.....	34
Troubleshooting External Connections.....	36
Troubleshooting Power Supply/Cooling Fan Modules.....	36
Troubleshooting Array Cooling Problems.....	37
Troubleshooting Expansion Enclosure Management Modules.....	37
If EMM Status LED is Blinking Amber (5 Times per Sequence)	38
If the EMM Status LED is Solid or Blinking Amber (2 or 4 Times per Sequence).....	38
If the Link Status LEDs are not Green.....	38
Troubleshooting RAID Controller Modules.....	38
If the Array Status LED is Solid or Blinking Amber.....	38
If Both LEDs for any Given FC IN Port are Unlit.....	39
Troubleshooting Physical Disks.....	39
Troubleshooting Array and Expansion Enclosure Connections.....	39
Troubleshooting a Wet System.....	40
Troubleshooting a Damaged System.....	41
Controller Failure Conditions.....	41
Critical Conditions.....	41

Noncritical Conditions.....	42
Invalid Storage Array.....	42
ECC Errors.....	42
PCI Errors.....	42
5 Technical Specifications.....	43
6 Getting help.....	47
Locating your system Service Tag.....	47
Contacting Dell.....	47
Documentation feedback.....	47

About Your System

Introduction

The MD3800f and MD3820f Series storage array is designed for high availability, offering redundant access to data storage. Its features support both single and dual RAID controller configurations.

The Dell PowerVault MD3800f and MD3820f Series storage array provides Fibre Channel (FC) connectivity to the host server. It enables access to 64 physical hosts.

The MD3800f and MD3820f Series storage array includes a number of components. These components are:

- RAID controller module(s)
- PSU/fan modules
- Disk drives (also called physical disks/hard drives in this document)
- A front bezel (optional)
- A system enclosure, into which the other components are plugged

Front-Panel Features and Indicators

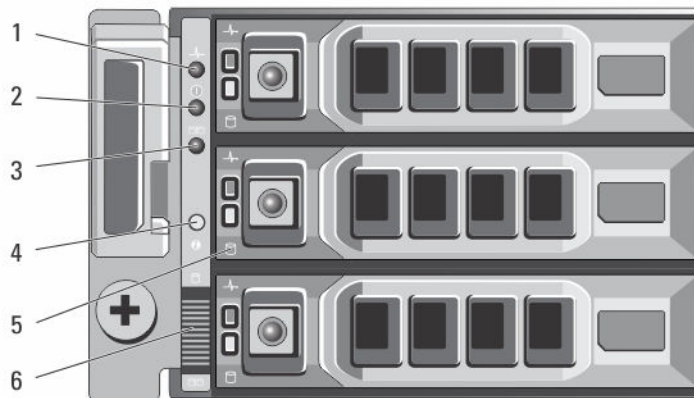

Figure 1. Front-Panel Features and Indicators—Dell PowerVault MD3800f



Figure 2. Front-Panel Features and Indicators—Dell PowerVault MD3820f

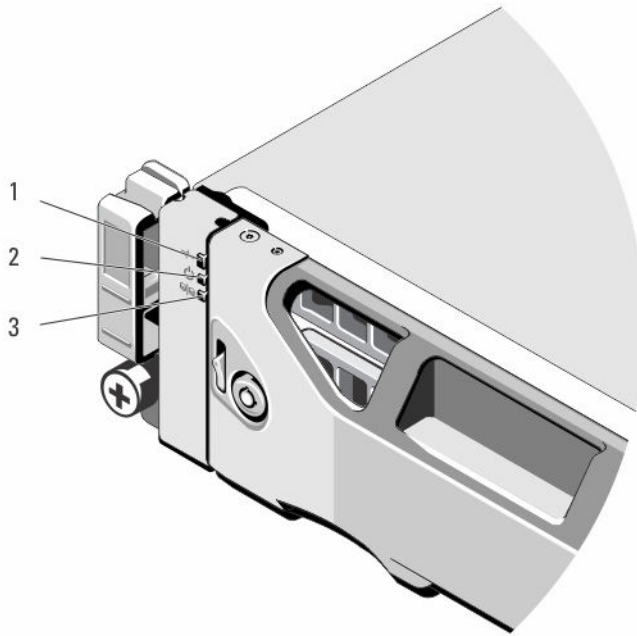



Figure 3. Front-Bezel Features and Indicators

Table 1. Front-Panel Features and Indicators

Item	Indicator, Button, or Connector	Description
1	Enclosure status LED	The enclosure status LED lights when the enclosure power is on. Lights blue during normal operation.

Item	Indicator, Button, or Connector	Description
		<p>Blinks blue when a host server is identifying the enclosure or when the system identification button is pressed.</p>
		<p>Lights amber as enclosure boots or is reset.</p>
		<p>Blinks amber when the enclosure is either in a fault state or the hosts are not using the preferred path to a virtual disk.</p>
2	Power LED	<p>The power LED lights green when at least one power supply is supplying power to the enclosure.</p>
3	Split mode LED	<p>This LED must be unlit as the split mode function is not supported by the MD3800f Series Storage Arrays.</p>
4	System identification button	<p>The system identification button on the front control panel can be used to locate a particular enclosure within a rack. When the button is pushed, the system status indicators on the control panel and the RAID controller module(s) blink blue until the button is pushed again.</p>
5	Hard drives	<p>MD3800f —Up to twelve 3.5 inch SAS hot-swappable hard drives. MD3820f —Up to twenty four 2.5 inch SAS hot-swappable hard drives.</p>
6	Enclosure mode switch	<p>The function of this switch is not applicable to your storage array. However, if MD1200 Series expansion enclosures are daisy chained to the storage array, the enclosure mode switches of the MD1200 Series expansion enclosures must be set to the Unified-Mode position.</p> <p> NOTE: This switch must be set before turning on the MD1200 Series expansion enclosure. Changing the switch setting after the expansion enclosure is turned on has no effect on the enclosure configuration until the expansion enclosure goes through a complete power cycle.</p>

Back-Panel Features and Indicators

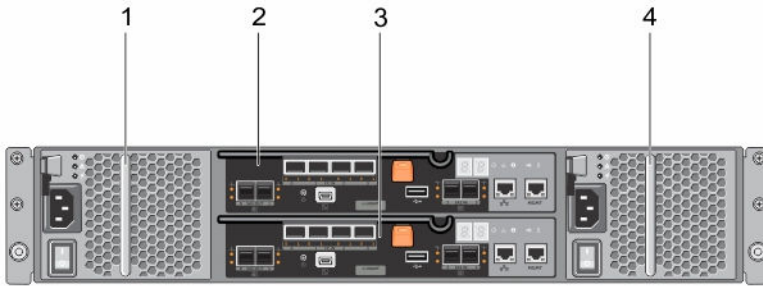

Figure 4. Back-Panel Features and Indicators—Dell PowerVault MD3800f and MD3820f Series

- | | |
|-----------------------------------|-----------------------------------|
| 1. 600 W power supply/cooling fan | 2. RAID Controller Module 0 |
| 3. RAID Controller Module 1 | 4. 600 W power supply/cooling fan |

Physical-Drive Indicator Patterns



Figure 5. Physical-Drive Indicators

- | | |
|--|--|
| 1. physical-drive activity indicator (green) | 2. physical-drive status indicator (green and amber) |
|--|--|

NOTE: If the physical drive is in Advanced Host Controller Interface (AHCI) mode, the status indicator (on the right side) does not function and remains off.

Table 2. Physical-Drive Indicators

Drive-Status Indicator Pattern (RAID Only)	Condition
Blinks green two times per second	Identifying drive or preparing for removal
Off	Drive ready for insertion or removal

Drive-Status Indicator Pattern (RAID Only) Condition

 **NOTE:** The drive status indicator remains off until all physical drives are initialized after the system is turned on. Drives are not ready for insertion or removal during this time.

Blinks green, amber, and turns off	Predicted drive failure
Blinks amber four times per second	Drive failed
Blinks green slowly	Drive rebuilding
Steady green	Drive online
Blinks green three seconds, amber three seconds, and turns off six seconds	Rebuild aborted

Power Supply and Cooling Fan Features

The MD3800f and MD3820f Series storage array includes two integrated, hot-swappable power supply/cooling fan modules. Both modules must be installed to ensure proper cooling. The system requires at least one of the cooling fans to function, to avoid overheating.

A power supply/cooling fan module can be replaced without powering down the system. For information on removing and installing the modules, see [Power Supply/Cooling Fan Module](#).

Power Indicator Codes and Features

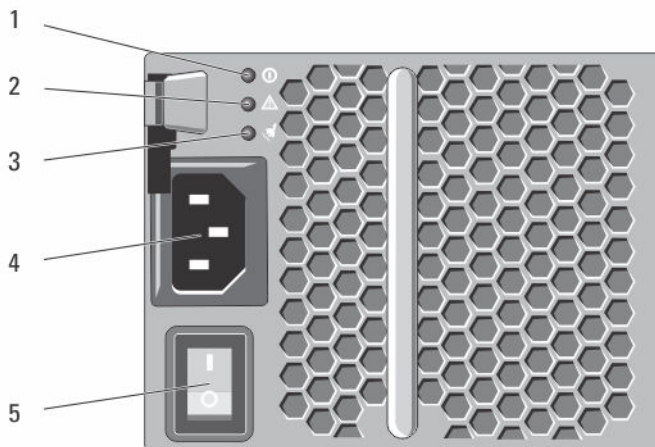





Figure 6. Power Indicator Codes and Features

Table 3. Power Indicator Codes and Features

Item	LED Type	Icon	Description
1	DC power		<p>The LED lights green when the DC output voltage is within the limit.</p> <p>If this LED is off, it indicates that the DC output voltage are not within the limit.</p>
2	Power supply/ cooling fan fault		<p>The LED lights amber when the DC output voltage is not within the limit or a fault with the fan is detected.</p> <p>If this LED is off, it indicates that no fault condition is present.</p>
3	AC power		<p>The LED lights green when the AC input voltage is within the limit.</p> <p>If this LED is off, it indicates either there is no power or the AC input voltage is not within the limit.</p>
4	Power connector		Connect the external power supply to this connector.
5	Power switches (2)		The power switch controls the power supply output to the enclosure.

Related Documentation



NOTE: For all PowerVault documentation, go to dell.com/powervaultmanuals.



NOTE: For all Dell OpenManage documents, go to dell.com/openmanagemanuals.



NOTE: For all storage controller documents, go to dell.com/storagecontrollermanuals.

You product documentation includes:

- *Dell PowerVault MD3400/3420/3800i/3820i/3800f/3820f Storage Arrays Getting Started Guide* — Provides an overview of system features, setting up your system, and technical specifications. This document is shipped with your system.
- Rack Installation Instructions — Describes how to install your system into a rack. This document is shipped with your rack solution.
- *Dell PowerVault MD Series Storage Arrays Administrator's Guide* — Provides information about configuring and managing the system using the MDSM GUI.
- *Dell PowerVault Modular Disk Storage Arrays CLI Guide* — Provides information about configuring and managing the system using the MDSM CLI.
- *Dell PowerVault MD3800f and MD3820f Storage Arrays Deployment Guide* — Provides information about deploying the storage system in the SAN architecture.
- *Dell PowerVault MD34xx and 38xx Series Support Matrix* — Provides information about the software and hardware compatibility matrices for the storage array.

Controller Modules

RAID Controller Modules

The RAID controller modules provide high-performance, advanced virtual disk configuration, and fault-tolerant disk subsystem management. Each RAID controller module contains 4GB or 8GB of mirrored cache for high availability and a battery-powered cache offload mechanism.

 **NOTE:** The 8GB mirrored cache is an optional feature.

RAID controller modules provide the following data path and enclosure management functions:

- Monitoring and controlling enclosure environment elements (temperature, fans, power supplies, and enclosure LEDs)
- Controlling access to the physical disks
- Communicating enclosure attributes and states to the host server and management station

Each RAID controller module has multiple Fibre Channel (FC) ports (labeled FC IN) for host access. The ports provide redundant host connections and support a high availability storage environment. Each port must have a small form-factor pluggable (SFP) transceiver module installed for connectivity. Various configurations can be utilized, in both single controller (simplex) and dual controller (duplex) modes, to connect the storage enclosure to hosts depending on specific redundancy needs.

For information on cabling, see the *MD3800f and MD3820f Series Storage Arrays Deployment Guide*, at dell.com/powervaultmanuals.

RAID Controller Module Connectors and Features

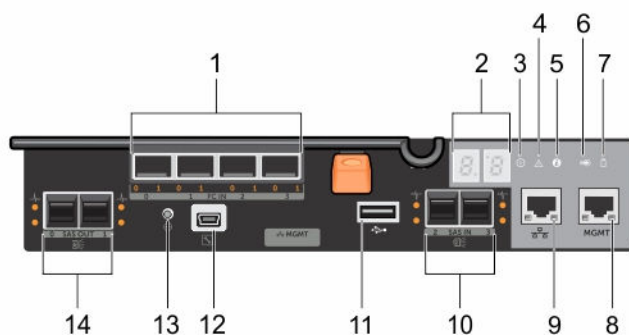



Figure 7. MD3800f and MD3820f Series Fibre Channel RAID Controller Module

Table 4. MD3400 and MD3420 Series SAS RAID Controller Module

Item	Component	Function
1	16 Gbps FC IN port (4)	Provides host-to-controller FC connection.
2	Seven segment display sequence	Displays status or error codes for the storage array.
3	Controller power LED	Lights green when controller power is on. Turns off when controller is not powered.
4	Controller fault LED	Lights amber when controller fault is detected. Turns off when controller is operating normally
5	System identification LED	Blinks blue when system identification switch push-button on enclosure front panel is pressed.
6	Cache active or cache offload LED	Lights green when on-board controller memory contains data. If AC power fails, this LED changes to indicate Cache Offload status. If the password reset function has successfully changed the password, this LED flashes on and off briefly.  NOTE: The password reset switch is not available if your system was shipped after September, 2015. The password reset switch functionality was disabled starting from controller firmware 08.20.09.60 and later versions.
7	Battery fault	Lights amber when battery backup unit or battery has failed. Turns off when battery backup unit is operating normally
8	Management port	Provides a 100/1000 Mbps Ethernet connection for out-of-band management of the enclosure.
9	Ethernet port (reserved)	Reserved port.
10	SAS IN port (2)	Provides host-to-controller SAS connection.
11	USB port	Does not provide any functionality.
12	Mini USB port	Reserved port.
13	Password reset switch	Activating this switch resets the password.

Item	Component	Function
		 NOTE: The password reset switch is not available if your system was shipped after September, 2015. The password reset switch functionality was disabled starting from controller firmware 08.20.09.60 and later versions.
14	SAS OUT port (2)	Provides SAS connection for cabling to a downchain expansion enclosure.

Host Channel LED Link Rate Indications

Below each FC port is a pair of LED indicators. The status of any FC port can be determined by applying the following table to the condition of each LED pair.

Table 5. Host Channel LED Link Rate Indications

LED 1	LED 0	CommRate
Off	Off	Link down
Off	On	2 Gbps
On	Off	4 Gbps
On	On	8 Gbps

RAID Controller Module—Additional Features

Battery Backup Unit

Each RAID controller contains a two-cell Lithium ion nanopolymer battery backup unit (BBU). It provides power to the RAID controller module in the event of a power outage. For information on removing and installing the BBU, see [RAID Controller Module Backup Battery Unit](#).

 **NOTE:** For virtual disks, the RAID controller firmware changes the data cache setting based on the state of the battery. If the battery is missing or does not have sufficient charge, the controller flushes the cache and sets the write cache attribute to **Write Through** for all virtual disks. When the battery is replaced, **Write Back** is re-enabled.

Storage Array Thermal Shutdown

The system automatically shuts down when system temperature exceeds the safe threshold. The battery backup unit protects against data loss by providing power to offload cache to non-volatile memory in the event of power loss. It is not necessary to shut down any MD1200 Series expansion enclosures attached to the storage array when thermal shutdown occurs.

Temperature threshold values determine the temperature at which shutdown occurs. These thresholds cannot be changed.

Table 6. Shutdown Threshold Type

Threshold Temperature Exceeding	Event Description
Nominal failure threshold	A critical event is set.
Maximum failure threshold	Shutdown of the system power supplies occurs within 3 minutes.
Shutdown threshold	Shutdown of the system power supplies occurs within 5 seconds.

System Password Reset

The storage array password can be reset if it is forgotten. To reset the password, push and hold down the password reset switch for at least 5 seconds. The password is deleted.

The RAID controller module allows you to change the password.

 **NOTE:** The reset switch can be accessed by using a small object such as the tip of a pen.

 **NOTE:** The password reset switch is not available if your system was shipped after September, 2015. The password reset switch functionality was disabled starting from controller firmware 08.20.09.60 and later versions.

Cache Functions and Features

Cache Mirroring

Cache mirroring function copies accepted host-write data from the primary controller to the partner controller. This action ensures that host-write data is safely mirrored to the partner controller before successful completion status is returned to the host. If a controller fails, the surviving controller safely retains all mirrored data. Cache mirroring is enabled by default.

Write-Back Cache

In write-back cache, write operations result in a completion signal being sent to the host operating system as soon as the cache receives the data to be written. The target physical disk receives the data at a more appropriate time to increase controller performance. In dual-active controller configurations with write-back caching enabled, the write data is always mirrored to the cache of the second controller before completion status is issued to the host initiator. Write-back cache is enabled by default unless cache mirroring is disabled.

Write-Through Cache

In write-through cache, data is written to the physical disk before completion status is returned to the host operating system. Write-through cache is considered more robust than write-back cache, since a

power failure is less likely to cause loss of data. The RAID controller automatically switches to write-through if cache mirroring is disabled, or if the battery is missing, or has a fault condition.

SFP Transceivers, Fiber Optic, and SAS Cables

FC host connections may operate at 16 Gbps or at a lower data rate. Ports for 16 Gbps FC host connections require SFP transceivers designed for this data rate. SFP transceivers that support other data rates are incompatible.

⚠ WARNING: Do not disassemble or remove any part of a small form-factor pluggable (SFP) transceiver due to the possibility of being exposed to laser radiation.

📌 NOTE: Your SFP transceivers and cables may look different from the ones shown below. The differences do not affect the performance of the SFP transceivers.

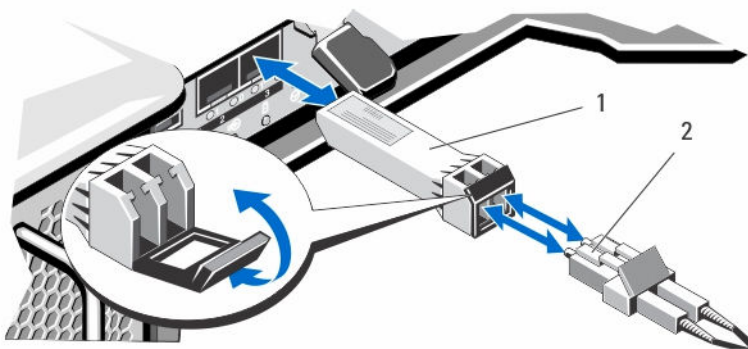

Figure 8. Fiber Optic Cable Connection

- 1. SFP transceiver
- 2. fiber optic cable

The RAID expansion ports support SAS expansion connections.

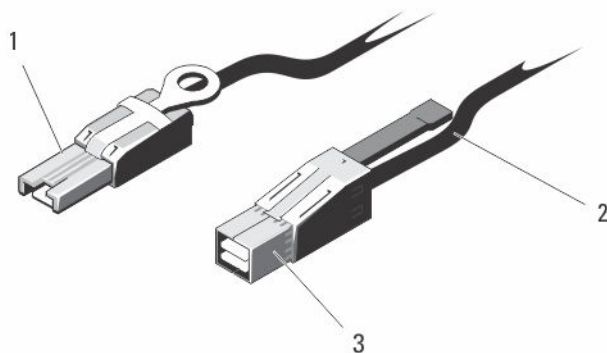

Figure 9. SAS Cable

- 1. mini SAS connector
- 2. SAS cable
- 3. mini SAS HD connector

Interoperability of 4 Gbps, 8 Gbps, and 16 Gbps Devices

The FC standard specifies a procedure for speedy autodetection. If an 8 Gbps port on a switch or device is connected to a 4 Gbps port, it must negotiate down for the link to run at 4 Gbps. If there are two 16 Gbps ports on either end of a link, the negotiation runs the link at 16 Gbps if the link supports the required specifications. If a link connects at 8 Gbps in this scenario, possible causes could be excessive cable length, poor cable quality, loose cables or SFPs, and so on. Ensure that the cable lengths are not excessive and the quality of the cable and connector is good.

Installing Array Components

Recommended Tools

You may need the following items to perform the procedures in this section:

- Key to the system keylock
- #2 Phillips screwdriver
- Wrist grounding strap

Front Bezel (Optional)

Removing the Front Bezel

1. Using the system key, unlock the front bezel (if locked).
2. Lift the release latch next to the keylock.
3. Rotate the left end of the bezel away from the front panel.
4. Unhook the right end of the bezel and pull the bezel away from the system.

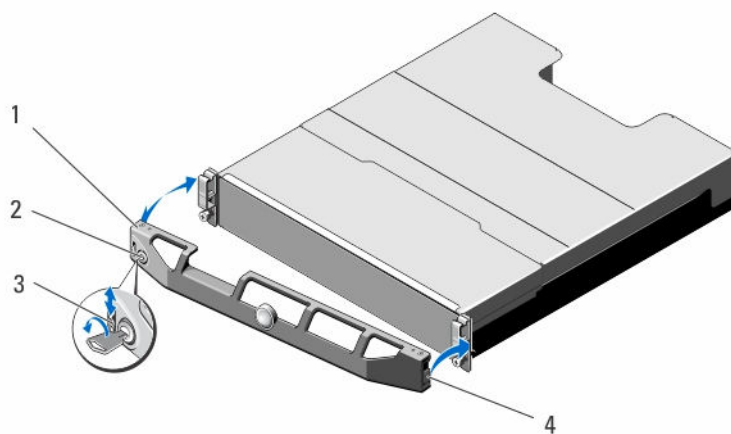

Figure 10. Removing and Installing the Front Bezel

- | | |
|------------------|--------------|
| 1. bezel | 2. keylock |
| 3. release latch | 4. hinge tab |

Installing the Front Bezel

1. Hook the right end of the bezel onto the chassis.
2. Fit the free end of the bezel onto the system.
3. Secure the bezel with the keylock.

Physical Drives

SAFETY Models AMT E03J and E04J

Models AMT, E03J, and E04J are intended for installation only in restricted access locations as defined in cl 1.2.7.3 of IEC 60950-1:2005.

Depending on your configuration, your array either supports up to twenty-four 2.5-inch SAS physical drives or up to twelve 3.5-inch SAS physical drives in internal drive bays. Physical drives are connected to a backplane through physical-drive carriers and can be configured as hot-swappable.

Removing a 2.5 Inch Physical-Drive Blank

△ CAUTION: To maintain proper system cooling, all empty physical-drive slots must have physical-drive blanks installed.

1. If installed, remove the front bezel.
2. Press the release button and slide the physical-drive blank out until it is free of the physical-drive slot.

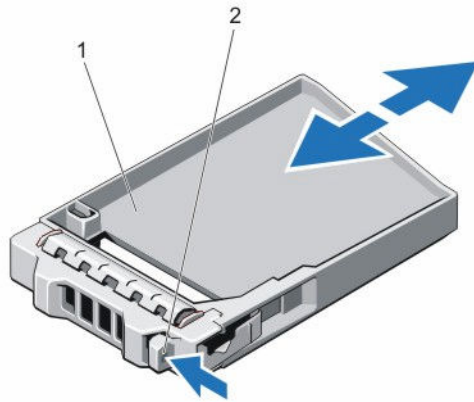

Figure 11. Removing and Installing a 2.5 Inch Physical-Drive Blank (MD3820f only)

1. physical-drive blank
2. release button

Installing a 2.5 Inch Physical-Drive Blank

1. If installed, remove the front bezel.
2. Insert the physical-drive blank into the physical-drive slot until the release button clicks into place.
3. If applicable, install the front bezel.

Removing a 3.5 Inch Physical-Drive Blank

△ CAUTION: To maintain proper system cooling, all empty hard-drive slots must have drive blanks installed.

1. If installed, remove the front bezel.
2. Press the release button and slide the physical-drive blank out until it is free from the physical-drive slot.

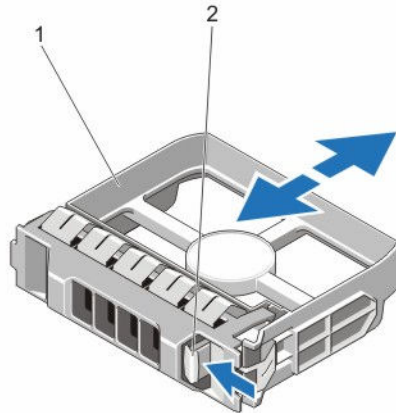

Figure 12. Removing and Installing a 3.5 Inch Hard-Drive Blank (MD3800f only)

1. physical-drive blank
2. release button

Installing a 3.5 Inch Physical-Drive Blank

1. If installed, remove the front bezel.
2. Insert the physical-drive blank into the physical-drive slot until the release button clicks into place.
3. If applicable, install the front bezel.

Removing a Hot-Swap Physical Drive

△ CAUTION: To prevent data loss, ensure that your operating system supports hot-swap drive installation. See the documentation supplied with your operating system.

1. From the management software, prepare the physical drive for removal. Wait until the indicators on the physical-drive carrier signal that the physical drive can be removed safely. For more information, see the documentation for the storage controller.

If the physical drive is online, the green activity/fault indicator flashes as the drive is turned off. When the physical-drive indicators are off, the physical drive is ready for removal.

2. Press the release button to open the physical-drive carrier release handle.
3. Slide the physical-drive carrier out until it is free of the physical-drive slot.

△ CAUTION: To maintain proper system cooling, all empty physical-drive slots must have physical-drive blanks installed.

4. Insert a physical-drive blank in the empty physical-drive slot.

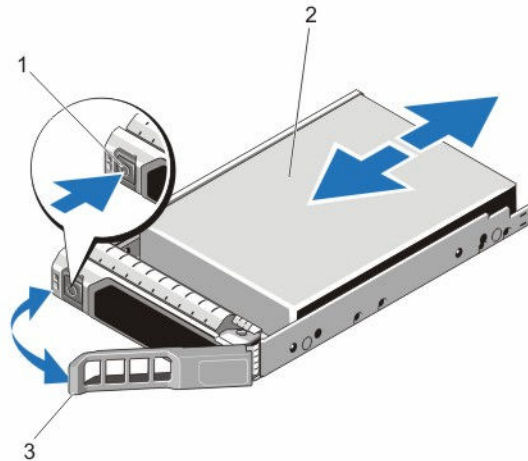

Figure 13. Removing and Installing a Hot-Swap Physical Drive

- | | |
|----------------------------------|-------------------|
| 1. release button | 2. physical drive |
| 3. physical-drive carrier handle | |

Installing a Hot-Swap Physical Drive

- △ **CAUTION:** Many repairs may only be done by a certified service technician. You should only perform troubleshooting and simple repairs as authorized in your product documentation, or as directed by the online or telephone service and support team. Damage due to servicing that is not authorized by Dell is not covered by your warranty. Read and follow the safety instructions that came with the product.
- △ **CAUTION:** Use only physical drives that have been tested and approved for use with the physical-drive backplane.
- △ **CAUTION:** Combining SAS and SATA physical drives in the same RAID volume is not supported.
- △ **CAUTION:** When installing a physical drive, ensure that the adjacent drives are fully installed. Inserting a physical-drive carrier and attempting to lock its handle next to a partially installed carrier can damage the partially installed carrier's shield spring and make it unusable.
- △ **CAUTION:** To prevent data loss, ensure that your operating system supports hot-swap drive installation. See the documentation supplied with your operating system.
- △ **CAUTION:** When a replacement hot swappable hard drive is installed and the system is powered on, the hard drive automatically begins to rebuild. Make absolutely sure that the replacement hard drive is blank or contains data that you wish to have over-written. Any data on the replacement hard drive is immediately lost after the hard drive is installed.

1. If a physical-drive blank is installed in the physical-drive slot, remove it.
2. Install a physical drive in the physical-drive carrier.
3. Press the release button on the front of the physical-drive carrier and open the physical-drive carrier handle.
4. Insert the physical-drive carrier into the physical-drive slot until the carrier connects with the backplane.
5. Close the physical-drive carrier handle to lock the physical drive in place.

Removing a Physical Drive From a Physical-Drive Carrier

1. Remove the screws from the slide rails on the physical-drive carrier.
2. Lift the physical drive out of the physical-drive carrier.

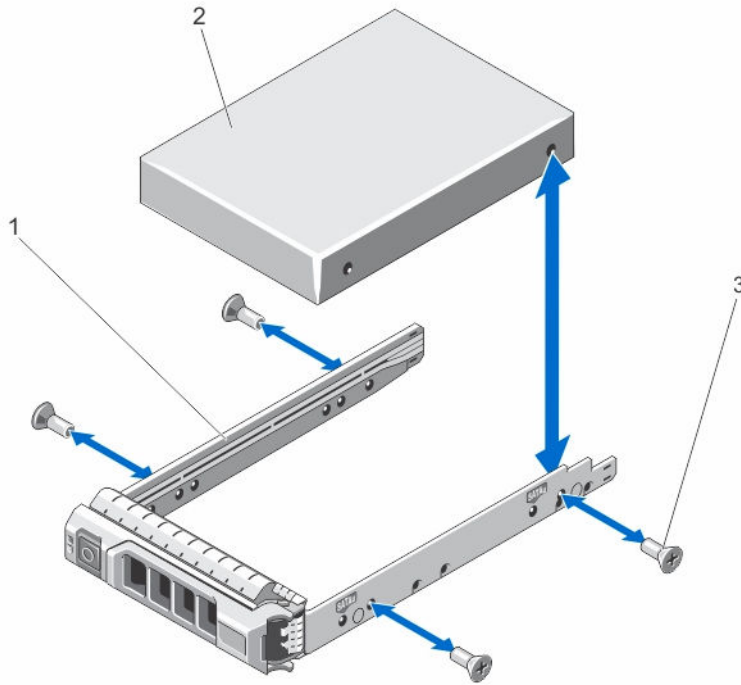

Figure 14. Removing and Installing a Physical Drive Into a 2.5 inch Physical-Drive Carrier

- | | |
|---------------------------|-------------------|
| 1. physical-drive carrier | 2. physical drive |
| 3. screws (4) | |

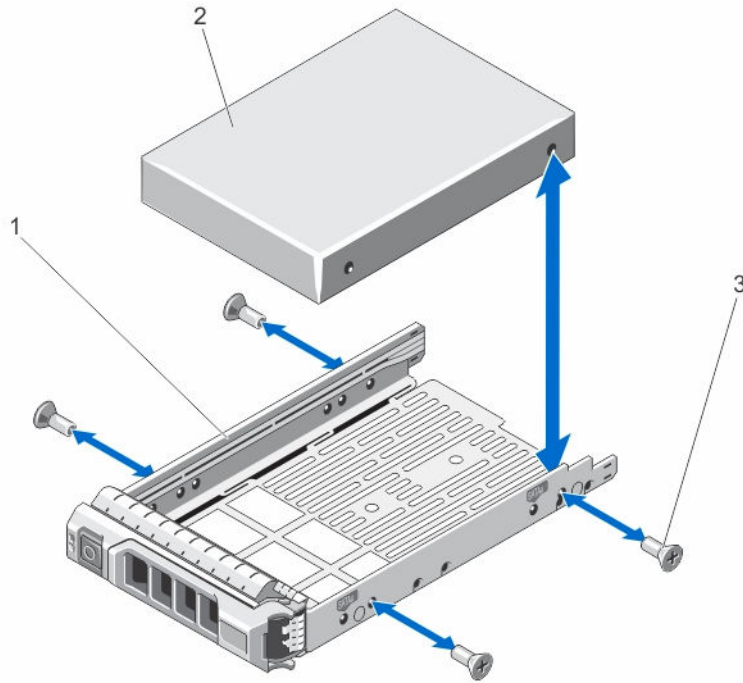

Figure 15. Removing and Installing a 3.5 Inch Physical Drive Into a Physical-Drive Carrier

- | | |
|---------------------------|-------------------|
| 1. physical-drive carrier | 2. physical drive |
| 3. screws (4) | |

Installing a Physical Drive Into a Physical-Drive Carrier

⚠ CAUTION: Many repairs may only be done by a certified service technician. You should only perform troubleshooting and simple repairs as authorized in your product documentation, or as directed by the online or telephone service and support team. Damage due to servicing that is not authorized by Dell is not covered by your warranty. Read and follow the safety instructions that came with the product.

1. Insert the physical drive into the physical-drive carrier with the connector end of the physical drive toward the back.
2. Align the screw holes on the physical drive with the back set of holes on the physical-drive carrier. When aligned correctly, the back of the physical drive is flush with the back of the physical-drive carrier.
3. Attach the screws to secure the physical drive to the physical-drive carrier.

RAID Controller Module

An MD3800f and MD3820f series storage array supports single as well as dual RAID controller configurations. If only one RAID controller module is installed in your array, it must be installed in slot 0. You must install the RAID controller module blank in slot 1.

△ CAUTION: RAID controller modules can be removed and installed without turning off the array. It is recommended that you do not remove the RAID controller module while data is being transferred. Replacing or installing a RAID controller module that is connected to a host server causes it to lose communication with the array and may require a reboot of the host server.

Removing a RAID Controller Module Blank

△ CAUTION: To maintain proper system cooling, you must install a RAID controller module blank in the empty slot.

1. Turn off the array and host server.
2. Disconnect all the power cables connected to the array.
3. To remove the RAID controller module blank, press down on the release latch and pull the blank away from the array.
4. Install RAID controller modules in slot 0 and 1.
5. Connect all the power cables to the array.
6. Turn on the array and the host server.

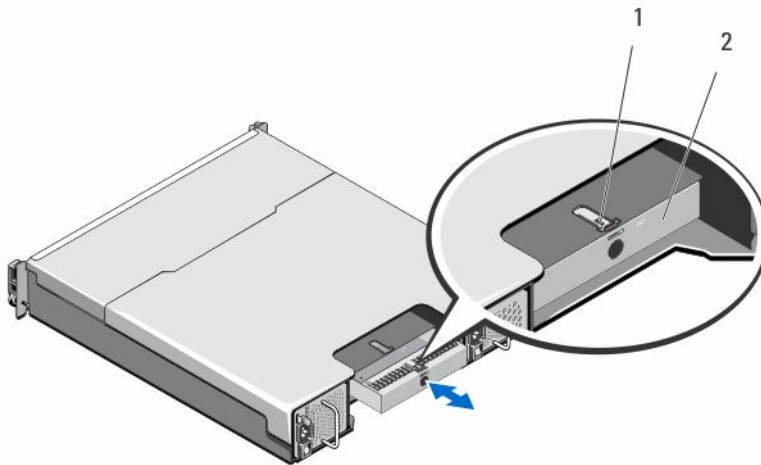

Figure 16. Removing and Installing a RAID Controller Module Blank

1. release latch

2. RAID controller module blank

Installing a RAID Controller Module Blank

1. Align the blank with the RAID controller module bay.
2. Insert the blank into the chassis until it clicks into place.

Removing a RAID Controller Module

△ CAUTION: Many repairs may only be done by a certified service technician. You should only perform troubleshooting and simple repairs as authorized in your product documentation, or as directed by the online or telephone service and support team. Damage due to servicing that is not authorized by Dell is not covered by your warranty. Read and follow the safety instructions that came with the product.

CAUTION: If your configuration uses fiber-optic cables, remember that they are fragile. Bending, twisting, folding, or pinching fiber-optic cables can cause damage to the cables, degraded performance, or loss of data. To prevent damage, do not twist, fold, pinch, or step on the cables. Do not bend the cables in less than a 5 cm (2 inch) radius.

1. If small form-factor pluggable (SFP) transceivers are present, record the ports in which they are installed, and remove them.
2. Take the desired RAID controller module offline.
3. Disconnect the cables connected to the RAID controller module.
If fiber-optic cables are present, it may be necessary to partially remove the RAID controller module using the two release levers. Opening the release levers makes it easier to press down the fiber-optic cable release tab.

4. Push down on the release tab and pull the release lever away from the chassis.
5. Grasp the release lever and pull the module away from the chassis.

NOTE: To avoid damage to the sensitive EMI contacts on the RAID controller module, do not stack RAID controller modules.

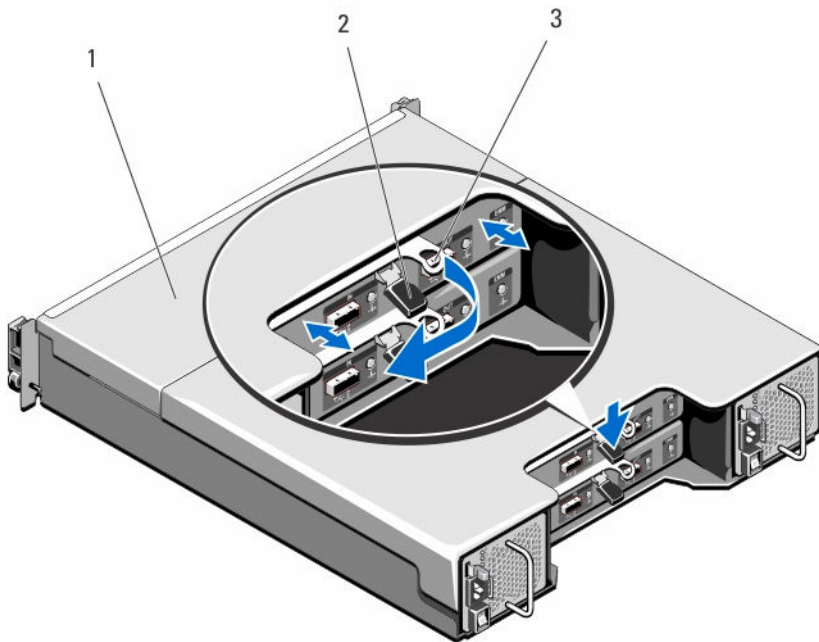

Figure 17. Removing and Installing a RAID Controller Module

1. RAID controller module
2. release tab
3. release lever

Installing a RAID Controller Module

WARNING: Fiber optic cables are fragile. Bending, twisting, folding, or pinching fiber optic cables can cause damage to the cables, degraded performance, or loss of data. To prevent damage, do not twist, fold, pinch, or step on the cables. Do not bend the cables in less than a 5 cm (2") radius.

CAUTION: Many repairs may only be done by a certified service technician. You must only perform troubleshooting and simple repairs as authorized in your product documentation, or as directed by the online or telephone service and support team. Damage due to servicing that is not authorized by Dell is not covered by your warranty. Read and follow the safety instructions that came with the product.

1. Insert the RAID controller module into the RAID controller module bay until it seats into place.
2. Push the release lever toward the chassis until it clicks into place.
3. Connect all the cables to the RAID controller module. If SFP transceivers and fiber optic cables were present, reinstall them in the correct ports.
4. If applicable, update the firmware for the RAID controller module. For information about the latest firmware, see dell.com/support.

Opening the RAID Controller Module

CAUTION: Many repairs may only be done by a certified service technician. You must only perform troubleshooting and simple repairs as authorized in your product documentation, or as directed by the online or telephone service and support team. Damage due to servicing that is not authorized by Dell is not covered by your warranty. Read and follow the safety instructions that came with the product.

1. Turn off the array and host server.
2. Disconnect all the power cables connected to the array.
3. Remove the RAID controller module.
4. Remove the screws from the sides of the RAID controller module.
5. While pressing the indent, slide the cover in the direction of the arrow and lift it away from the RAID controller module.

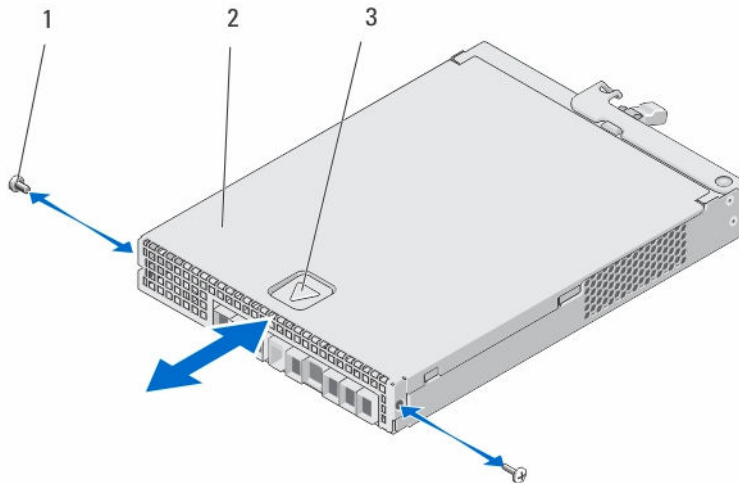

Figure 18. Opening and Closing the RAID Controller Module

1. screws (2)
2. RAID controller module
3. indent

Closing the RAID Controller Module

△ CAUTION: Many repairs may only be done by a certified service technician. You must only perform troubleshooting and simple repairs as authorized in your product documentation, or as directed by the online or telephone service and support team. Damage due to servicing that is not authorized by Dell is not covered by your warranty. Read and follow the safety instructions that came with the product.

1. Place the cover onto the RAID controller module and offset it slightly towards the back, so that the hooks on the cover fit over the corresponding slots on the RAID controller module.
2. Slide the cover toward the front till it snaps into place.
3. Replace the screws on the RAID controller module.
4. Connect all the cables to the array. If SFP transceivers and fiber optic cables were previously in place, reinstall them in the correct ports.
5. Turn on the array and the host server.

RAID Controller Module Backup Battery Unit

Removing the RAID Controller Module Backup Battery Unit

△ CAUTION: Many repairs may only be done by a certified service technician. You must only perform troubleshooting and simple repairs as authorized in your product documentation, or as directed by the online or telephone service and support team. Damage due to servicing that is not authorized by Dell is not covered by your warranty. Read and follow the safety instructions that came with the product.

1. Turn off the array and host server.
2. Disconnect all the cables connected to the array.
3. Remove the RAID controller module.
4. Open the RAID controller module.
5. Loosen the screw that secures the backup battery unit to the RAID controller module.
6. Slide the backup battery unit and lift it out of the RAID controller module.

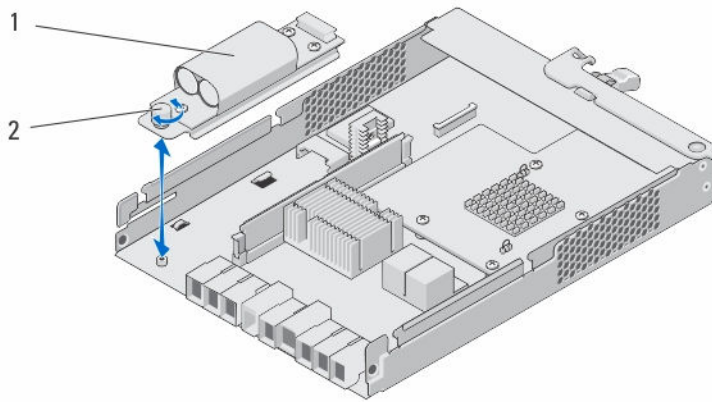

Figure 19. Removing and Installing the RAID Controller Module Backup Battery Unit

- 1. backup battery unit
- 2. screw

Installing the RAID Controller Module Backup Battery Unit

⚠ CAUTION: Many repairs may only be done by a certified service technician. You must only perform troubleshooting and simple repairs as authorized in your product documentation, or as directed by the online or telephone service and support team. Damage due to servicing that is not authorized by Dell is not covered by your warranty. Read and follow the safety instructions that came with the product.

1. Align the backup battery unit with the slots on the RAID controller module.
2. Slide the backup battery unit toward the connector on the RAID controller module.
3. Tighten the screw that secures the backup battery unit to the RAID controller module.
4. Close the RAID controller module.
5. Replace the RAID controller module.
6. Connect all the cables to the array.
7. Turn on the array and the host server.

Power Supply/Cooling Fan Module

🔧 NOTE: Your storage array includes two integrated, hot-swappable power supply/cooling fan modules.

The array supports two hot-swappable power supply/cooling fan modules. While the array can operate temporarily with one module, both the modules must be present for proper system cooling.

⚠ CAUTION: A single power supply/cooling fan module can be removed from a powered-on array for a maximum period of 5 minutes. Beyond that time, the array may automatically shut down to prevent damage.

Removing a Power Supply/Cooling Fan Module

⚠ CAUTION: Many repairs may only be done by a certified service technician. You must only perform troubleshooting and simple repairs as authorized in your product documentation, or as directed by the online or telephone service and support team. Damage due to servicing that is not authorized by Dell is not covered by your warranty. Read and follow the safety instructions that came with the product.

🔧 NOTE: If you remove a fully functioning power supply/cooling fan module, the fan speed in the remaining module increases significantly to provide adequate cooling. The fan speed decreases gradually when a new power supply/cooling fan module is installed.

1. Turn off the power supply/cooling fan module.
2. Disconnect the power cable from the power source.
3. Remove the straps that secure the power cable and disconnect the power cable from the power supply/cooling fan module.

⚠ WARNING: The power supply/cooling fan modules are heavy. Use both hands while removing the module.

4. Press the release tab and pull the power supply out of the chassis.

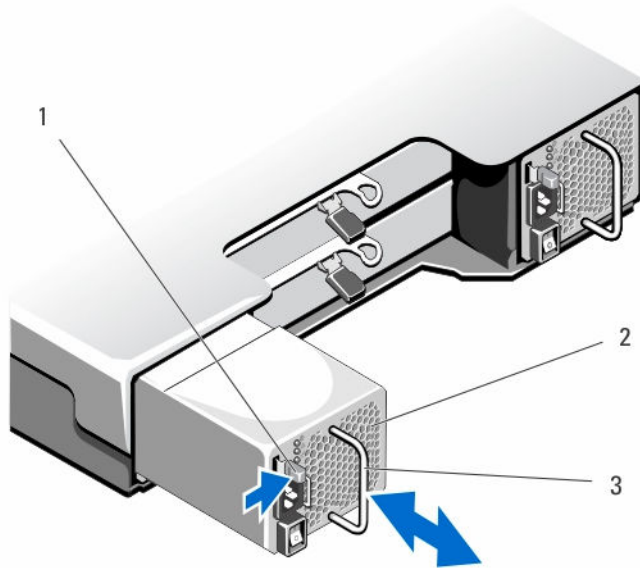

Figure 20. Removing and Installing a Power Supply/Cooling Fan Module

1. release tab
2. power supply
3. power supply handle

Installing a Power Supply/Cooling Fan Module

△ CAUTION: Many repairs may only be done by a certified service technician. You must only perform troubleshooting and simple repairs as authorized in your product documentation, or as directed by the online or telephone service and support team. Damage due to servicing that is not authorized by Dell is not covered by your warranty. Read and follow the safety instructions that came with the product.

1. Slide the power supply/cooling fan module into the chassis until it is fully seated and the release tab clicks into place.
2. Connect the power cable to the power supply/cooling fan module and plug the cable into a power outlet.
3. Secure the power cable using the strap.

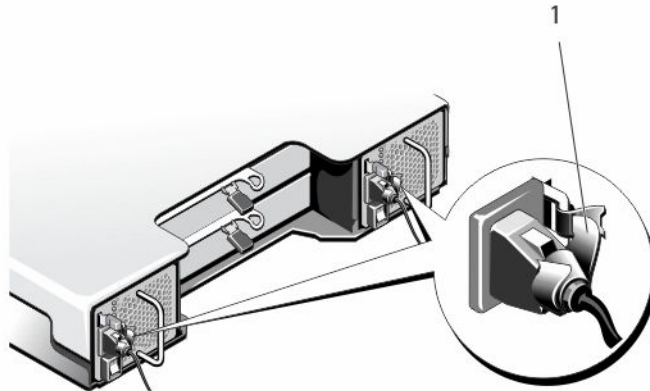

Figure 21. Securing the Power Cable

1. restraining strap

△ CAUTION: When connecting the power cable, secure the cable with the strap.

✎ NOTE: If the array is powered on, all the power supply LEDs remain off until the AC power cable is connected to the power supply/cooling fan module and the power switch is turned on.

4. Turn on the power supply/cooling fan module.

Control Panel

Removing the Control Panel

1. Turn off the array and host server.
2. Disconnect all the power cables connected to the array.
3. Remove the hard drives from:
 - slots 0 to 2 in PowerVaultMD3800f.
 - slots 0 to 5 in PowerVaultMD3820f.

✎ NOTE: Mark each hard drive with its slot position as you remove it.

4. Slide the control panel out of the chassis after:

5. Turn on the array and the host server.

Backplane

Removing the Backplane

CAUTION: Many repairs may only be done by a certified service technician. You must only perform troubleshooting and simple repairs as authorized in your product documentation, or as directed by the online or telephone service and support team. Damage due to servicing that is not authorized by Dell is not covered by your warranty. Read and follow the safety instructions that came with the product.

1. Turn off the array and disconnect it from the electrical outlet.
2. Disconnect all the cables connected to the array.
3. Remove the hard drives.
4. Remove the RAID controller modules.
5. Remove the power supply/cooling fan modules.
6. Remove the control panel.
7. Remove the screws that secure the RAID controller module/power supply cage to the chassis.
8. Hold the cage removal ring at the bottom center of the array and pull the RAID controller module/power supply cage toward the back of the chassis.
9. Lift the RAID controller module/power supply cage away from the chassis.
10. Loosen the captive screw that secures the backplane to the chassis.
11. Remove the screws that secure the backplane and pull the backplane out of the array.

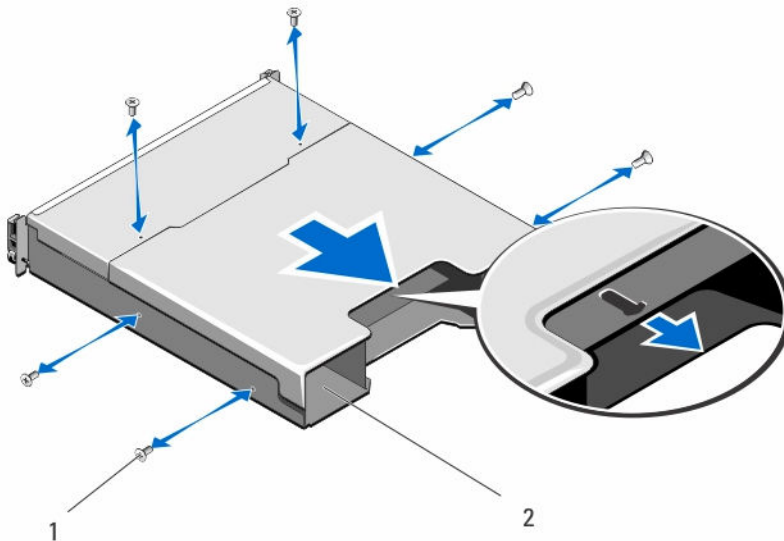

Figure 24. Removing and Installing the RAID Controller Module/Power Supply Cage

1. screws (6)

2. RAID controller module/power supply cage

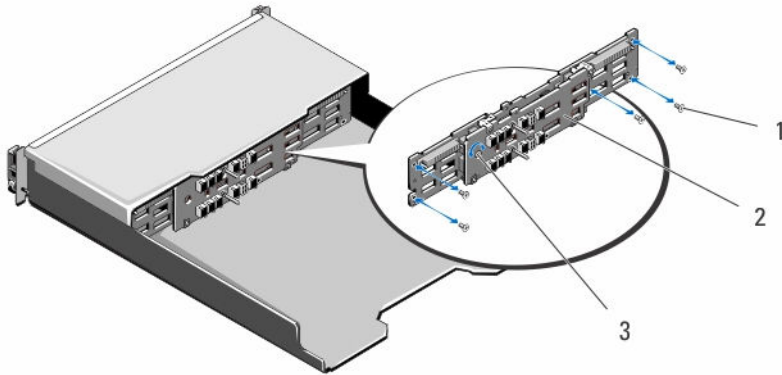

Figure 25. Removing and Installing the Backplane—PowerVault MD3800f

- | | |
|------------------|--------------|
| 1. screws (5) | 2. backplane |
| 3. captive screw | |

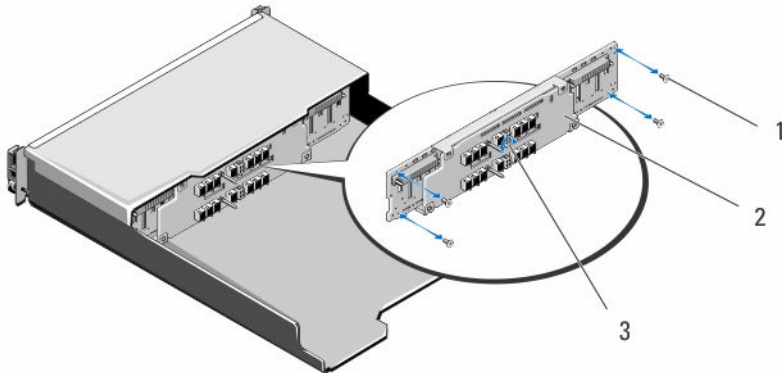

Figure 26. Removing and Installing the Backplane—PowerVault MD3820f



- | | |
|------------------|--------------|
| 1. screws (4) | 2. backplane |
| 3. captive screw | |

Installing the Backplane

1. Align the screw holes on the backplane with the screw holes on the array.
2. Tighten the captive screw to secure the backplane to the chassis.
3. Replace the screws that secure the backplane to the chassis.
4. Align the slots on the RAID controller module/power supply cage with the tabs on the chassis.
5. Push the RAID controller module/power supply cage toward the front of the array.
6. Replace the screws that secure the RAID controller module/power supply cage to the chassis.
7. Replace the control panel.
8. Replace the power supply/cooling fan modules.
9. Replace the hard drives.
10. Connect all the cables to the array.
11. Turn on the array and the host server.

Troubleshooting Your System

Safety First—For You and Your System

-  **CAUTION:** Many repairs may only be done by a certified service technician. You should only perform troubleshooting and simple repairs as authorized in your product documentation, or as directed by the online or telephone service and support team. Damage due to servicing that is not authorized by Dell is not covered by your warranty. Read and follow the safety instructions that came with the product.
-  **NOTE:** To replace a RAID controller, always hot plug the replacement controller when the array has been powered on.
- All new hard drives should be hot plugged to the array.
- Do not use drives or RAID controllers from other arrays.

Troubleshooting Storage Array Startup Failure



If your system halts during startup, check if:

- The array emits a series of beeps.
 - The array fault LEDs are lit.
 - There is a constant scraping or grinding sound when you access the physical disk.
- For assistance, contact Dell Support.

Troubleshooting Loss of Communication

For information about troubleshooting loss of communication, see [Troubleshooting Array and Expansion Enclosure Connections](#).

Troubleshooting an SFP Transceiver

-  **NOTE:** This section is applicable only for the Dell PowerVault MD3800f and MD3820f storage enclosures.
-  **WARNING:** Data processing environments can contain equipment transmitting on system links with Laser modules that operate at greater than Class 1 power levels. Never look into the end of an optical fibre cable or open receptacle.
-  **CAUTION:** When handling static-sensitive devices, take precautions to avoid damaging the product from static electricity.

 **NOTE:** Before proceeding with this section, see **Working With SFP Modules And Fibre Optic Cables** in the *Dell PowerVault MD3800f and MD3820f Series Storage Arrays Deployment Guide* at dell.com/powervaultmanuals.

 **NOTE:** Equip yourself with antistatic protection and a replacement small form-factor pluggable (SFP) transceiver before replacing an SFP transceiver in the RAID controller module. Also, see the initial setup information for the enclosure to verify LED definitions.

 **CAUTION:** To prevent degraded performance, do not twist, fold, pinch, or step on fibre optic cables. Do not bend the fibre optic cables tighter than a 5 cm (2 inch) radius.

1. If possible, use the MD Storage Manager to create, save, and print a new storage array profile.
2. If the Recovery Guru directed you to replace a failed RAID controller module, go to step 3, else run the Recovery Guru to identify the failed component.
3. Unpack the new SFP transceiver.

 **NOTE:** Ensure that the SFP transceiver is replaced by the same type.

 **NOTE:** Set the new SFP transceiver on a dry, level surface near the RAID controller module, the RAID controller module enclosure, or the expansion enclosure.

 **NOTE:** Save all the packing materials in case you need to return the SFP transceiver.

4. To locate a failed SFP transceiver, view the FC IN (host channel) speed LEDs on the front of the RAID controller modules. If an SFP transceiver has failed, both FC IN speed LEDs for a particular port are off.
 - If both FC IN speed LEDs are off for a particular port with a known good cable, the SFP transceiver must be replaced. Go to step 6.
 - If at least one FC IN speed LED is on for a particular port, the SFP transceiver is functional. The FC IN speed LEDs indicate a channel speed of 4 Gbps, 8 Gbps, or 16 Gbps. Ensure that the speed indicated by the LEDs is what is expected.

 **WARNING:** Data processing environments can contain equipment transmitting on system links with laser modules that operate at greater than Class 1 power levels. Never look into the end of an optical fiber cable or open receptacle.

 **CAUTION:** To prevent degraded performance, do not twist, fold, pinch, or step on fiber optic cables. Do not bend the fiber optic cables tighter than a 5 cm (2 inch) radius.

5. If present, disconnect the fiber optic cable from the failed SFP transceiver.
6. Remove the failed SFP transceiver from the interface port.

 **CAUTION:** It is recommended that you turn off the host server before turning off the array to prevent loss of data.

1. Locate the faulty power supply and determine the status of the LEDs.
 - If the AC power LED is not lit, check the power cord and power source into which the power supply module is plugged.
 - Connect another device to the power source to verify if it is working.
 - Connect the cable to a different power source.
 - Replace the power cable. If the problem is not resolved, see [Getting Help](#).
 - If the DC power LED is not lit, verify that the power switch is turned on. If the power switch is turned on, see step 2.
 - If the power supply module's fault indicator is lit, see [Getting Help](#).

 **CAUTION:** Power supply modules are hot-swappable. The array can operate on a single power supply module; however both modules must be installed to ensure proper cooling. A single power supply module can be removed from a powered-on array for a maximum period of five minutes. Beyond that time, the array may automatically shut down to prevent damage.

2. Reseat the power supply module by removing and reinstalling it.

 **NOTE:** After installing a power supply module, allow several seconds for the array to recognize the power supply module and to determine if it is working properly.

If the problem is not resolved, see [Getting Help](#).

Troubleshooting Array Cooling Problems

 **CAUTION:** Many repairs may only be done by a certified service technician. You should only perform troubleshooting and simple repairs as authorized in your product documentation, or as directed by the online or telephone service and support team. Damage due to servicing that is not authorized by Dell is not covered by your warranty. Read and follow the safety instructions that came with the product.

Ensure that none of the following conditions exist:

- Array cover or drive blank is removed.
- External airflow is obstructed.
- The cooling fan module is removed or has failed.

If the problem is not resolved, see [Getting Help](#).

Troubleshooting Expansion Enclosure Management Modules

 **CAUTION:** Many repairs may only be done by a certified service technician. You should only perform troubleshooting and simple repairs as authorized in your product documentation, or as directed by the online or telephone service and support team. Damage due to servicing that is not authorized by Dell is not covered by your warranty. Read and follow the safety instructions that came with the product.

 **CAUTION:** It is recommended that you turn off the host server before turning off the expansion enclosure array to prevent loss of data.

If EMM Status LED is Blinking Amber (5 Times per Sequence)

Update the firmware to the latest supported firmware on both the EMMs. For more information on updating your EMM firmware, see Management Firmware Downloads in the Storage Arrays Administrator's Guide at dell.com/powervaultmanuals.

If the EMM Status LED is Solid or Blinking Amber (2 or 4 Times per Sequence)

1. Turn off the host server.
2. Remove the EMM and verify that the pins on the backplane and EMM are not bent.
3. Reseat the EMM module and wait for 30 seconds.
4. Turn on the host server.
5. Check the EMM status LED.
6. If the LED does not turn Green, replace the EMM.

If the problem is not resolved, see [Getting Help](#).

If the Link Status LEDs are not Green

1. Turn off the host server.
2. Reseat the cables on the expansion array and the server.
3. Turn on the expansion arrays and the storage array and wait until the system is fully booted.
4. Turn on the host server.
5. Check the link status LED. If the link status LED is not green, replace the cables.

If the problem is not resolved, see [Getting Help](#).

Troubleshooting RAID Controller Modules

 **CAUTION:** Many repairs may only be done by a certified service technician. You should only perform troubleshooting and simple repairs as authorized in your product documentation, or as directed by the online or telephone service and support team. Damage due to servicing that is not authorized by Dell is not covered by your warranty. Read and follow the safety instructions that came with the product.

 **CAUTION:** In the case of non-redundant configurations, it is recommended that you turn off the host server before turning off the array to prevent loss of data.

If the Array Status LED is Solid or Blinking Amber

1. In the AMW, select the **Summary** tab, and click on **Storage Array needs attention**.
2. Follow the listed procedures in the Recovery Guru(s) and wait for up to 5 minutes to check if the LED has turned blue.
If following the Recovery Guru procedures does not solve the problem, complete the following procedure to further troubleshoot the array.
3. Turn off the host server as appropriate.

4. Remove the RAID controller module and verify that the pins on backplane and RAID controller module are not bent.
5. Reinstall the RAID controller module and wait for 30 seconds.
6. Check the RAID controller module status LED.
7. Replace the RAID controller module.
8. Turn on the host server.

If the problem is not resolved, see [Getting Help](#).

If Both LEDs for any Given FC IN Port are Unlit

1. Turn off the host server, storage arrays, and expansion enclosures.
2. Reseat the RAID controller module and reconnect cables on the storage array and the host server.
3. Restart the storage array and wait until the array is fully booted.
4. Turn on the host server.
5. Recheck the LEDs of the affected port(s). Replace the fibre optic cables of any port(s) where both LEDs are unlit.

 **NOTE:** The SAS OUT status LED must be green.

If the problem is not resolved, see [Getting Help](#).

Troubleshooting Physical Disks

 **CAUTION:** Many repairs may only be done by a certified service technician. You should only perform troubleshooting and simple repairs as authorized in your product documentation, or as directed by the online or telephone service and support team. Damage due to servicing that is not authorized by Dell is not covered by your warranty. Read and follow the safety instructions that came with the product.

1. Check the storage array profile to ensure that the most current version of the firmware is installed. For more information, see the Support Matrix at dell.com/support/manuals.
2. Remove the physical disk from the system.

 **NOTE:** You must ensure that you check the physical disk indicators before removing the faulty physical disk from the system.

3. Check the physical disks and the midplane to ensure that the connectors are not damaged.
4. Reinstall the physical disk.
5. If the problem is not resolved, replace the failed physical disk.

If the problem persists, see [Getting Help](#).

Troubleshooting Array and Expansion Enclosure Connections

1. Verify the following:
 - the SAS OUT status LED is green
 - for each FC IN port connected to a cable, at least one of the paired LEDs is on
2. Ensure that all the cables are attached correctly according to the array mode you selected.

3. Turn off the host server, storage array, and expansion enclosures.
4. Reseat the RAID controller module and reconnect cables on the storage array and the host server.
5. Turn on the expansion arrays and then the storage array and wait until the system is fully booted.
6. Turn on the host server.
7. Check the LEDs of all cabled ports. Replace the fibre optic cables of any port(s) where both LEDs are unlit.
8. Reboot the host server.

 **NOTE:** You must turn off the host server before resetting the cables on the storage array or expansion enclosure.

If the problem is not resolved, see [Getting Help](#).

Troubleshooting a Wet System

 **CAUTION:** Many repairs may only be done by a certified service technician. You should only perform troubleshooting and simple repairs as authorized in your product documentation, or as directed by the online or telephone service and support team. Damage due to servicing that is not authorized by Dell is not covered by your warranty. Read and follow the safety instructions that came with the product.

1. Turn off the system and attached peripherals, and disconnect the system from the electrical outlet.
2. Open the system.
3. Disassemble components from the system:
 - Hard drives
 - Hard-drive backplane
 - USB memory key
 - Cooling shroud
 - Expansion-card risers (if present)
 - Expansion cards
 - Power supply(s)
 - Cooling-fan assembly (if present)
 - Cooling fans
 - Processor(s) and heat sink(s)
 - Memory modules
4. Let the system dry thoroughly for at least 24 hours.
5. Reinstall the components you removed in step 3.
6. Close the system.
7. Turn on the system and attached peripherals.
If the system does not start properly, see [Getting Help](#).
8. If the system starts properly, shut down the system and reinstall all of the expansion cards that you removed.
9. Run the appropriate diagnostic test. For more information, see Using System Diagnostics.

If the tests fail, see [Getting Help](#).

Troubleshooting a Damaged System

 **CAUTION:** Many repairs may only be done by a certified service technician. You should only perform troubleshooting and simple repairs as authorized in your product documentation, or as directed by the online or telephone service and support team. Damage due to servicing that is not authorized by Dell is not covered by your warranty. Read and follow the safety instructions that came with the product.

1. Turn off the system and attached peripherals, and disconnect the system from the electrical outlet.
2. Open the system.
3. Ensure that the following components are properly installed:
 - Cooling shroud
 - Expansion-card risers (if present)
 - Expansion cards
 - Power supply(s)
 - Cooling-fan assembly (if present)
 - Cooling fans
 - Processor(s) and heat sink(s)
 - Memory modules
 - Hard-drive carriers
 - Hard-drive backplane
4. Ensure that all cables are properly connected.
5. Close the system.
6. Run the appropriate diagnostic test. For more information, see Using System Diagnostics.

If the tests fail, see [Getting Help](#).

Controller Failure Conditions

Certain events can cause a RAID controller module to fail and/or shut down. Unrecoverable ECC memory or PCI errors, or critical physical conditions can cause lockdown. If your RAID storage array is configured for redundant access and cache mirroring, the surviving controller can normally recover without data loss or shutdown.

Critical Conditions

The storage array generates a critical event if the RAID controller module detects a critical condition that could cause immediate failure of the array and/or loss of data. The storage array is in a critical condition if one of the following occurs:

- More than one fan has failed
- Any midplane temperature sensors in the critical range
- Midplane/power supply module failure
- Two or more temperature sensors are unreadable
- Failure to detect or unable to communicate with peer port

 **NOTE:** If both RAID controller modules fail simultaneously, the enclosure cannot issue critical or noncritical event alarms for any enclosure component.

Noncritical Conditions

A noncritical condition is an event or status that does not cause immediate failure, but must be corrected to ensure continued reliability of the storage array. Examples of noncritical events include the following:

- One power supply module has failed
- One cooling fan module has failed
- One RAID controller module in a redundant configuration has failed
- A battery has failed or has been removed
- A physical disk in a redundant virtual disk has failed

Invalid Storage Array

The RAID controller module is supported only in a Dell-supported storage array. After installation in the storage array, the controller performs a set of validation checks. The array status LED is lit with a steady amber color while the RAID controller module completes these initial tests and the controllers are booted successfully. If the RAID controller module detects a non-Dell supported storage array, the controller does not start up. The RAID controller module does not generate any events to alert you in the event of an invalid array, but the array status LED is lit with a flashing amber color to indicate a fault state.

ECC Errors

RAID controller firmware can detect ECC errors and can recover from a single-bit ECC error whether the RAID controller module is in a redundant or non-redundant configuration. A storage array with redundant controllers can recover from multi-bit ECC errors as well because the peer RAID controller module can take over, if necessary.

The RAID controller module fails over if it experiences up to 10 single-bit errors, or up to three multi-bit errors.

PCI Errors

The storage array firmware can detect and only recover from PCI errors when the RAID controller modules are configured for redundancy. If a virtual disk uses cache mirroring, it fails over to its peer RAID controller module, which initiates a flush of the dirty cache.

Technical Specifications

Table 7. Physical Disks

Physical disks	Up to twelve 3.5 inch or twenty-four 2.5 inch SAS, nearline SAS physical disks, or SAS SSDs
----------------	---

Table 8. RAID Controller Modules

RAID controller modules	Two hot-swappable modules with temperature sensors 4GB or 8GB of cache per controller
	Provides host-to-controller 16G FC connection

Table 9. Expansion Modules







Dell PowerVault MD1200 and MD1220 expansion enclosures	Each expansion enclosure holds Up to twelve 3.5 inch or twenty-four 2.5 inch SAS, nearline SAS physical disks, or SAS SSDs Redundant path connectivity provides redundant data paths to each hard drive
	 NOTE: Support for 192 physical disks is a premium feature and requires activation.
SAS connectors	Two SAS IN ports to connect hosts One SAS OUT port for expansion to additional PowerVault MD1200 or MD1220 expansion enclosure
	 NOTE: SAS connectors are SFF-8088 compliant.
Serial connector (debug port)	One 6-pin mini-DIN connector
	 NOTE: For technical support use only.

Table 10. Back-Panel Connectors (Per RAID Controller Module)

SAS connectors	Two SAS OUT ports for expansion to an additional PowerVault MD1200 or MD1220 expansion enclosures
	 NOTE: SAS connectors are SFF-8088 compliant.
	 NOTE: It is recommended that you use one port.
FC connectors	Four FC IN ports to connect hosts

Serial connector (debug port)

One mini-USB port

 **NOTE:** For technical support use only.

Management Ethernet connector

One 100/1000 Mbps Ethernet connection for out-of-band management of the enclosure (MGMT)

Table 11. Power

AC power supply (per power supply)

Wattage 600 W

Heat dissipation (maximum) 100 W

 **NOTE:** Heat dissipation is calculated using the power supply wattage rating. The heat dissipation values are for the entire system which includes chassis and two controllers.

Voltage 100–220 V AC, (8.6 A–4.3 A)

 **NOTE:** This system is also designed to be connected to IT power systems with a phase to phase voltage not exceeding 230 V.

Battery 6.6 V DC, 1100 mAh, 7.26 W Lithium ion battery

Table 12. Environmental

 **NOTE:** For additional information about environmental measurements for specific system configurations, see dell.com/environmental_datasheets.

Temperature

Operating Continuous operation: 10 °C to 35 °C (50 °F to 95 °F) at 20% to 80% relative humidity (RH), with 26 °C maximum dew point. De-rate maximum allowable dry bulb temperature at 1 °C/300 m (1 °F per 550 ft) above 900 m (2952.75 ft).

 **NOTE:** For information on supported expanded operating temperature range and configurations, see the Owner's Manual at dell.com/powervaultmanuals.

Storage –40 °C to 65 °C (–40 °F to 149 °F) with a maximum temperature gradation of 20 °C per hour

Relative humidity

Operating 10% to 80% (noncondensing) with maximum humidity gradation of 10% per hour



Storage	5% to 95% at a maximum wet bulb temperature of 33 °C (91 °F)
Maximum vibration	
Operating	0.26 G_{rms} at 5 Hz to 350 Hz in operational orientation
Storage	1.88 G_{rms} at 10 Hz to 500 Hz for 15 minutes (all six sides tested)
Maximum shock	
Operating	One shock pulse in the positive z axis of the system at 31 G for 2.6 ms in the operational orientation
Storage	Six consecutively executed shock pulses in the positive and negative x, y, and z axes (one pulse on each side of the system) at 71 G for up to 2 ms
Altitude	
Operating	Maximum 3000 m (9842.5 ft)
	 NOTE: For altitudes above 2950 ft, the maximum operating temperature is derated 1.8 °F/1000 ft.
Storage	Maximum 12192 m (40,000 ft)
Airborne contaminant level	
Class	G1 as defined by ISA-S71.04-1985

Table 13. Particulate Contamination

 **NOTE:** This section defines the limits to help avoid IT equipment damage and/or failure from particulates and gaseous contamination. If it is determined that levels of particulates or gaseous pollution are beyond the limits specified below and are the reason for the damage and/or failures to your equipment, it may be necessary for you to re-mediate the environmental conditions that are causing the damage and/or failures. Re-mediation of environmental conditions will be the responsibility of the customer.

Air Filtration

Data center air filtration as defined by ISO Class 8 per ISO 14644-1 with a 95% upper confidence limit.

 **NOTE:** Applies to data center environments only. Air filtration requirements do not apply to IT equipment designed to be used outside a data center, in environments such as an office or factory floor.

 **NOTE:** Air entering the data center must have MERV11 or MERV13 filtration.

Conductive Dust

Air must be free of conductive dust, zinc whiskers, or other conductive particles.

 **NOTE:** Applies to data center and non-data center environments.

Corrosive Dust

- Air must be free of corrosive dust.



NOTE: Applies to data center and non-data center environments.

- Residual dust present in the air must have a deliquescent point less than 60% relative humidity.

Getting help

Locating your system Service Tag

Your system is identified by a unique Express Service Code and Service Tag number. The Express Service Code and Service Tag are found on the front of a physical DR Series system by pulling out the information tag. This can also be found on the support tab in the GUI. This information is used by Dell to route support calls to the appropriate personnel.

Contacting Dell

 **NOTE:** If you do not have an active Internet connection, you can find contact information on your purchase invoice, packing slip, bill, or Dell product catalog.

Dell provides several online and telephone-based support and service options. Availability varies by country and product, and some services may not be available in your area. To contact Dell for sales, technical support, or customer service issues:

1. Go to **dell.com/support**.
2. Select your support category.
3. Verify your country or region in the **Choose a Country/Region** drop-down list at the bottom of the page.
4. Select the appropriate service or support link based on your need.

Documentation feedback

Click the **Feedback** link in any of the Dell documentation pages, fill out the form, and click **Submit** to send your feedback.